

Simulation of high altitude environment



Application note A054-ME09-0716A

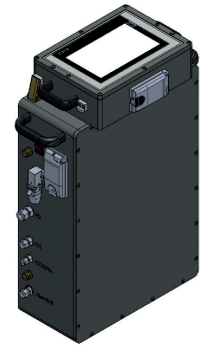

photo: Sheppard Air Force Base

- ◆ Pilot training
- ◆ High-altitude research

As humans, we perform at our best by an atmospheric pressure that contains about 21% oxygen. As a result, a lower oxygen pressure has some detrimental mental and physical effects. These effects mainly manifest at high altitudes with a low total pressure. This phenomenon is known as hypoxia.

A government department investigates hypoxia and places human test subjects in a low-pressure chamber, under medical supervision. The conditions at high altitude are simulated by lowering the absolute pressure to a value that equals the specific altitude, but it is rather harsh for the body. Moreover, as the CO₂ level inside the human body is a major regulator of respiration, one line of investigation is by adding CO₂ to artificial breathing air at atmospheric conditions. The latter is difficult to implement at low pressure. Bronkhorst was able to realise a solution in cooperation with a system integrating company.



Compact gas supply system

Application requirements

As an alternative for the low-pressure chamber, a solution has to be found at atmospheric pressure where well-defined gas mixtures can be supplied. So air constituents such as oxygen, nitrogen and carbon dioxide have to be supplied independently from each other to a human test subject.

This supply has to be conducted in an accurate, repeatable and well-controlled way, to be sure that the desired N₂/O₂/CO₂ mixture really has been supplied. Furthermore, a possibility to document the test conditions and results is required.

Important topics

- ◆ Accurate dosing of air constituents
- ◆ Documentation of test conditions
- ◆ Repeatability
- ◆ Compact system

Process solution

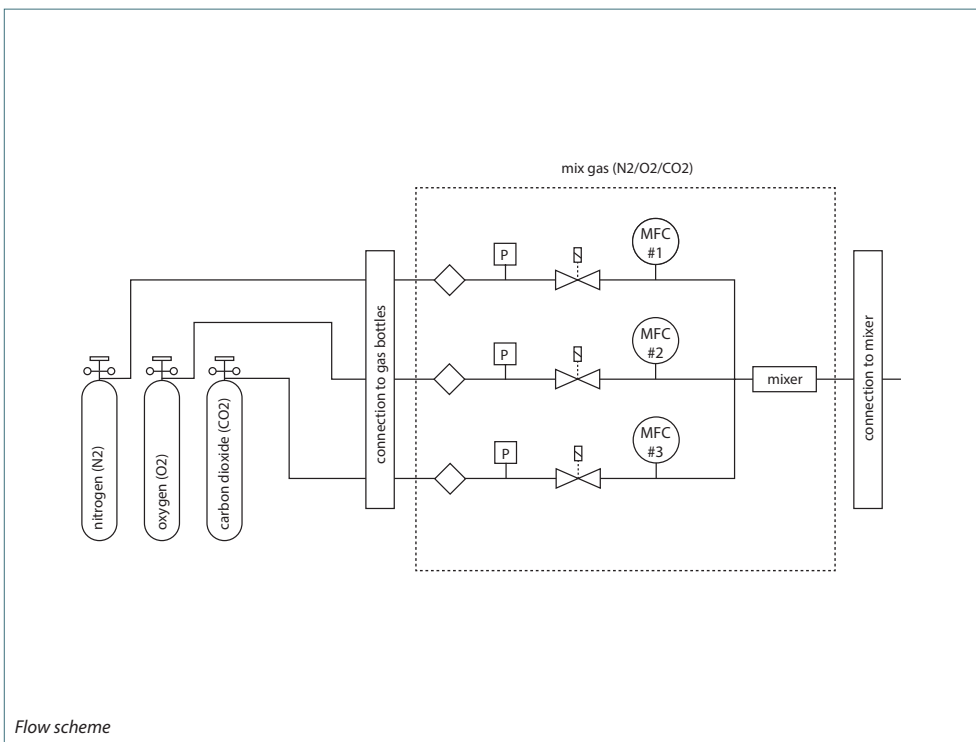

Flow scheme

Bronkhorst delivered three thermal mass flow controllers for accurately supplying nitrogen, oxygen and carbon dioxide. The system integrating company placed these controllers together with a gas mixing chamber and the controlling & monitoring (PLC) system in a compact box. During operation, the gas mixture was supplied to the human test subject via a mask that covered both nose and mouth. In this way, a complete solution has been realised for the government department. Using this setup, which works at atmospheric pressure, human test subjects no longer have to be subjected to low total pressures, making it easy for the human body, and carbon dioxide can be supplied in various contents as a constituent of artificial breathing air.

The control unit can be configured to deliver any desired mixture of nitrogen, oxygen and carbon dioxide. The setup allows an accurate analysis of specific gas mixture concentrations, and tests have demonstrated that is done in a repeatable way. Furthermore, under different circumstances - i.e. the equivalent of several altitudes, including sea level - reproducible results can be obtained. Using this system, the process is easily monitored and relevant data such as the actual delivered gas mixture are well documented.

Based on these results, Bronkhorst and the system integrating company actually met the targets set. This was also due to the high flexibility of the system and its low initial costs. Due to this success, the government department is evaluating additional systems for similar tests in different locations. ■

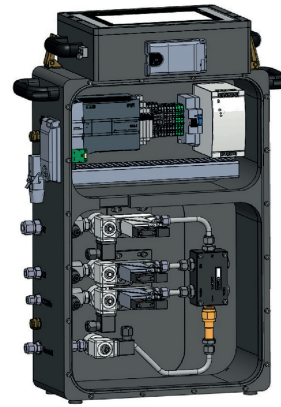

Compact gas supply system with the control unit on top and three MFCs in the bottom part

Recommended Products



EL-FLOW Select

EL-FLOW Select Series Mass Flow Meters/Controllers are thermal mass flow meters of modular construction with a 'laboratory style' pc-board housing. Control valves can either be integrally or separately mounted, to measure and control gas flows from lowest range 0,014...0,7 mln/min up to highest range 8...1670 ln/min.

- ◆ High accuracy (standard 0,5% Rd plus 0,1% FS)
- ◆ Rangeability in digital mode up to 1:187,5
- ◆ Fast response (down to 500 msec), excellent repeatability
- ◆ Optional Multi-Gas / Multi-Range functionality: freely programmable ranges and gas types
- ◆ Pressure ratings 64 / 100 bar (Multi-Gas / Multi-Range functionality up to 10 bar)
- ◆ Compact, modular construction

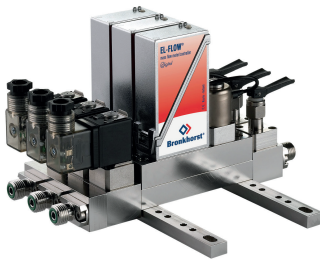

FLOW-SMS

On a compact, lightweight but still rugged mounting rail system one or more mass flow or pressure sensor modules can be combined with any other functional module. The ranges for the flow sensor can be selected between approx. 5 mln/min up to 50 ln/min or even higher. In case a pressure sensor is included, the pressure range can be chosen between 0-100 mbar and 0-10 bar absolute or gauge.

- ◆ Compact assembly ensures space efficiency
- ◆ Economical solution, low cost of ownership
- ◆ Tubeless construction reduces potential leak points
- ◆ Service friendly; easily accessible from the top
- ◆ Great flexibility regarding system extension or modification
- ◆ Analog or digital communication

Contact information



Simulation of high altitude environment

A054-ME09-0716A

ME: Medical
09: Other medical applications

T +31(0)573 45 88 00 F +31(0)573 45 88 08
I www.bronkhorst.com E info@bronkhorst.com